

SMX70



NEW

**AUTOMATIC
TYRE CHANGER WITH
LOCKING CAPACITY
UP TO 27"**

**SMONTAGOMME
AUTOMATICO
CON CAPACITÀ
DI BLOCCAGGIO
FINO A 27"**



CEMB

GARAGE EQUIPMENT

SMX70

- 1 ■ Automatic tyre changer with pneumatic **rear tilting post** granting the maximum rigidity to prevent rim damage.
- Smontagomme automatico con **palo ribaltabile pneumaticamente** che garantisce la massima rigidità per non danneggiare il cerchio.



- 3 ■ **Reinforced base vertical post structure** and 60x60 mm horizontal arm grant maximum rigidity. Simultaneous vertical and horizontal arm locking system, vertical arm with spring return.

- **Struttura palo rinforzata** e braccio orizzontale avente dimensione 60x60 mm che garantisce la massima rigidità riducendo ogni possibile flessione. Sistema di bloccaggio simultaneo di asta verticale e braccio orizzontale con ritorno a molla dell'asta.



- 4 ■ Self-centering turntable to ease bead-breaking of the second tyre bead. Rim locking through opposed-jaws device (**10"- 27" range**), with 80 mm diameter cylinders, which guarantees an optimal grip on all types of rims. Jaws with replaceable tips. New swivel fitting (> speed).

- Piatto autocentrante per agevolare il detallonamento del secondo tallone. Sistema di bloccaggio cerchio (**capacità da 10" a 27"**) a griffe contrapposte con cilindri di Ø 80 mm, che garantisce una forza di serraggio ottimale su tutti i tipi di cerchi. Griffe con punte sostituibili. Nuovo raccordo girevole (>velocità).

- 5 ■ **Bead breaker** with ergonomic arm to operate on **wheels of 17" in width**.
- **Stallatore** ergonomico per operare su **ruote da 17" di larghezza**.

- 6 ■ Body **with removable pedal unit** for easy maintenance. Pedals positioned in line (rotation included).

- Telaio con **pedaliera estraibile**, per facilitare le operazioni di manutenzione. Pedali posizionati in linea (rotazione inclusa).

- 7 ■ Motor controlled by the new **Motoinverter system with progressive variation of speed**. The inverter board is installed on the machine, away from the engine to overcome vibration and heat problems. Low power consumption at rest (intelligent stand-by). High reliability and protection, with automatic alarm reset bringing the pedal to the resting position (no power outages required).

- Motore controllato dal nuovo **sistema Motoinverter con variazione progressiva della velocità**. La scheda inverter è installata sulla macchina, lontano dal motore per evitare problemi di vibrazioni e surriscaldamento. Basso consumo energetico a riposo (stand-by intelligente). Elevata affidabilità e protezione, con ripristino automatico dell'allarme che porta il pedale in posizione di riposo (non è richiesta alcuna interruzione di corrente).



- 8 ■ **Large and useful tool holder** with differentiated compartments to store the various tools.

- **Ampio e utile portaoggetti** a scomparti differenziati per riporre i vari utensili.

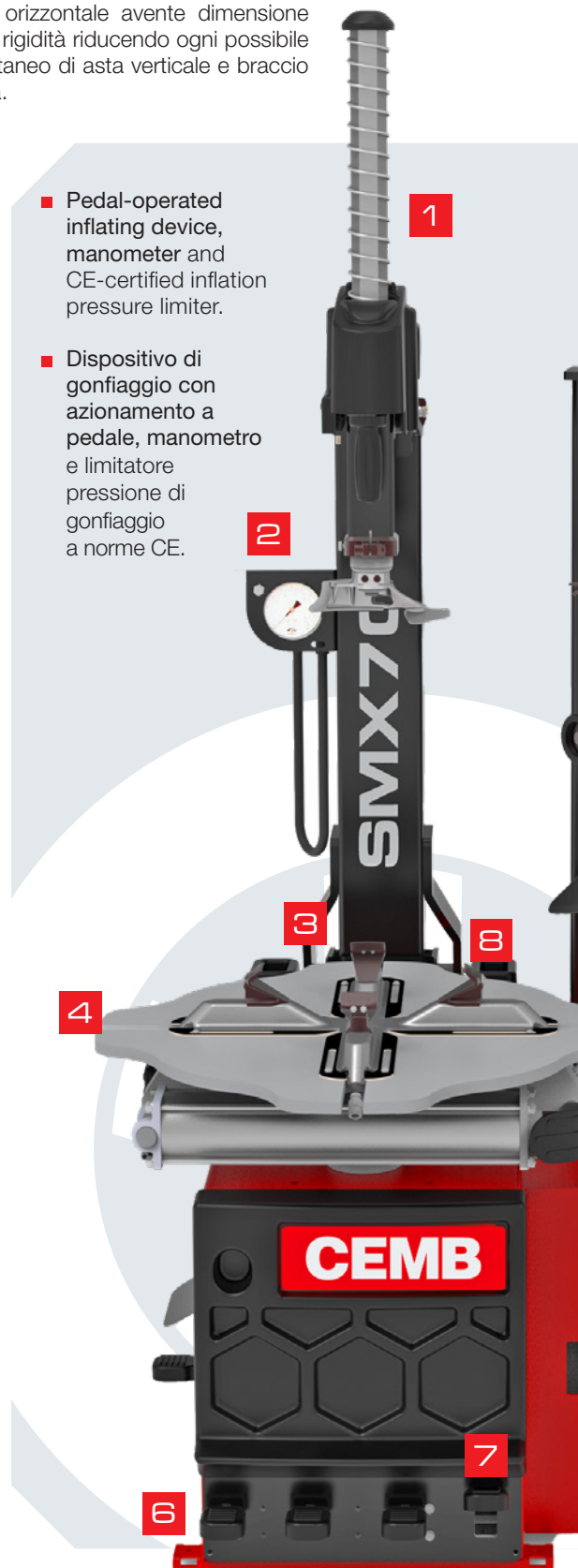

- 1 ■ **Pedal-operated inflating device, manometer and CE-certified inflation pressure limiter.**

- 2 ■ **Dispositivo di gonfiaggio con azionamento a pedale, manometro e limitatore pressione di gonfiaggio a norme CE.**

4

2

1

3

8

CEMB

6

7

VERSIONS
ON REQUEST

VERSIONI
A RICHIESTA



TI-VERSION

Version with an effective inflation device for bead seating integrated in clamping jaws.

Versione dotata di efficace sistema di gonfiaggio tubeless incorporato nelle griffe, per l'intallamento dello pneumatico.

A-VERSION

A Version with pneumatic positioning of tool arm.

Versione A con posizionamento pneumatico del braccio porta utensile.

OPTIONAL ACCESSORIES ACCESSORI OPZIONALI

HPX-STD

- Professional compact side presser **HPX-STD** recommended to operate on particularly hard and large-sized Run-Flat and UHP Tyres. Compact structure, designed with 1 air cylinder Ø 80 mm to avoid bendings.
- Pressore laterale professionale **HPX-STD** raccomandato per operare su ruote Run-Flat e UHP particolarmente duri e di grandi dimensioni. Struttura compatta progettata con un cilindro ad aria Ø 80 mm che non subisce flessioni.

HPX-ADVANCE

- Professional lateral presser **HPX-ADVANCE** ideal to operate on particularly hard and large-sized Run-Flat and UHP Tyres. Robust structure with 2 air cylinders of 80 mm to avoid bendings. Equipped with rim pressing tool, standard bead pressing roller arm, bead pressing roller at 90° with pneumatic locking and possibility of operating under the tyre.
- Pressore laterale professionale **HPX-ADVANCE** ideale per operare su ruote Run-Flat e UHP particolarmente duri e di grandi dimensioni. Struttura robusta progettata con 2 cilindri ad aria da 80 mm che non subiscono flessioni. Dotato di premicerchio, un rullo premitallone classico ed un rullo premitallone a 90° con bloccaggio pneumatico e possibilità di operare sul tallone inferiore.

HPX-FA

- Additional bead-pushing device **HPX-FA** which assists during the mounting and demounting of the upper bead. It is recommended on tyres and rims with large diameters and sizes.
- Premitalone addizionale **HPX-FA**. Aiuta in fase di montaggio e smontaggio del tallone superiore. Raccomandato per ruote di grandi dimensioni.



STANDARD ACCESSORIES - ACCESSORI STANDARD



Bead lever
Leva



Front head protection (x2)
Protezione frontale utensile (x2)



Rear head protection (x2)
Protezione ala utensile (x2)

OPTIONAL ACCESSORIES - ACCESSORI OPZIONALI



Wheel Lift
Sollevatore



Roller board
Kit rulliera



Tubeless inflation system
Sistema di gonfiaggio TI



4 jaws ALU protection kit
Kit 4 pezzi protezioni ALU per griffe



Bead breaker blade protection
Protezione paletta



Plastic lever protection
Protezione leva in plastica



Run Flat clamp
Pinza Run Flat



Jaws for motorcycle wheels 14" ÷ 24"
Kit griffe moto 14" ÷ 24"



Jaws for scooter wheels 8" ÷ 14"
Kit griffe scooter 8" ÷ 14"

TECHNICAL DATA - DATI TECNICI

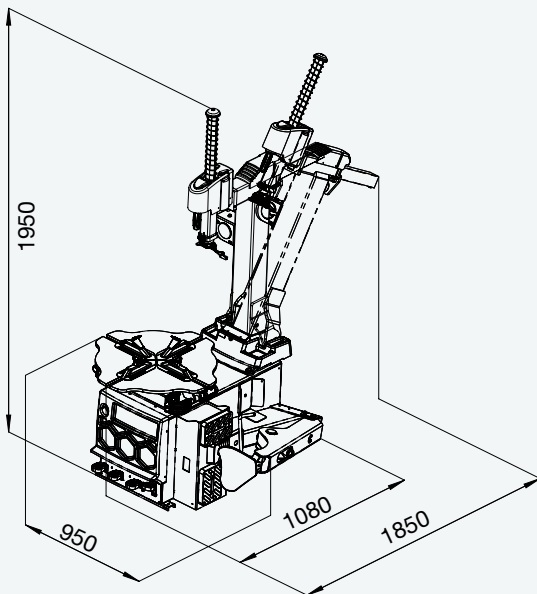

Clamping capacity
Internal clamping
External clamping
Max wheel diameter
Max wheel width
Bead breaker force
1-Phase motor
3-Phase motor
Turntable speed
Operating pressure
Noise level
Net weight

Capacità di bloccaggio	10" ÷ 27" (min ÷ max)
Bloccaggio interno	12" - 27"
Bloccaggio esterno	10" - 24"
Diametro massimo ruota	1170 mm (46")
Larghezza massima ruota	430 mm (17")
Forza stallonatore	15000N
Potenza motore monofase	1.5 kW (Inverter) 230V 50-60Hz
Potenza motore trifase	0.75 kW 400V - 50/60 Hz (2 speed)
Velocità di rotazione	0 - 16 rpm (1ph - Inverter)
	8 - 16 rpm (3ph - 2 speed)
Pressione di esercizio	8 - 10 bar (116 - 145 psi)
Livello di rumorosità	< 70 ± 3 dB (A)
Peso netto	270 kg



CEMB

BALANCING MACHINES

CEMB S.p.A.

Via Risorgimento, 9
23826 Mandello del Lario (LC) - Italy

www.cemb.com



Garage equipment division
CEMB - ITALY
Plant and Training Center
Phone +39 0341 706111
garage@cemb.com

CEMB USA - BL Systems Inc.
2873 Ramsey Road
Gainesville, GA 30501 - USA
Phone +001 678 717 1050
Fax +001 678 717 1056
sales@cemb-usa.com

All the data and features mentioned in this catalogue are purely for information and do not constitute any commitment on the part of our company, which reserves the right to make any and all alterations it may consider suitable without notice.